

**INNOVATION.
NOT DUPLICATION.™**



CRUSHING SOLUTIONS

LINER DEVELOPMENT PROGRAM

H-E PARTS INTERNATIONAL (H-E PARTS) SPECIALIZES IN PROVIDING WEAR MANAGEMENT SOLUTIONS. H-E PARTS LINER DEVELOPMENT PROGRAM HAS BEEN DEVELOPED TO OPTIMIZE LINER DESIGNS ON A SITE BY SITE BASIS AND INVOLVES THE ONGOING ANALYSIS OF SITE OPERATIONAL REQUIREMENTS, MACHINE OPERATING PARAMETERS, AND WORN LINER PROFILES.

H-E Parts International (H-E Parts), crusher liner development program provides systematic, ongoing product development of our customers' crusher liner sets and goes above and beyond standard industry practice of trialling a set of liners.

Utilizing state-of-the-art laser scanning in conjunction with H-E Parts ChamberVision™ and CrusherVision™ software, H-E Parts dedicated engineering specialists are able to accurately predict wear performance in cone, jaw and gyratory crushers to provide customized solutions to suit site-specific requirements.

CUSTOMER BENEFITS

By ensuring that the design is right at a very early stage, H-E Parts is able to:

Supply liners that will provide site-specific performance and life by design, based on end user requirements (e.g. liner sets can be designed to coincide with site-specific shutdown schedules)

- Reduce the need for expensive condition monitoring
- Ensure consistent, predictable crusher performance throughout the design life
- Ensure consistent performance between sets over time
- Minimize risk of premature failure through pre-installation wear simulations
- Implement ongoing improvements to accommodate changing feed conditions, to ensure that liners continue to provide optimum performance

ENGINEERING SERVICE

THE H-E PARTS PROCESS FOR DESIGNING SITE-SPECIFIC LINERS IS:

- 1. OBTAINING CRUSHER PARAMETERS, FEED DATA, CURRENT LINER SET LIFE AND PERFORMANCE THEN ESTABLISHING CUSTOMER TARGET GOALS.**
- 2. A H-E PARTS TECHNICIAN VISITS THE CUSTOMER SITE TO SCAN THE NEW AND WORN LINERS.**
- 3. SITE-SPECIFIC WEAR DATA IS EXTRACTED FROM THESE SCANS AND FED INTO OUR PROPRIETARY WEAR SIMULATION AND MODELING SOFTWARE.**
- 4. LINERS ARE THEN DESIGNED BASED ON SITE-SPECIFIC APPLICATIONS TO ACHIEVE CUSTOMER PERFORMANCE TARGETS, AT THE LOWEST TOTAL OPERATING COST.**

CHAMBERVISION™

CHAMBERVISION™ WEAR SIMULATION

H-E Parts International (H-E Parts), crusher liner development program provides systematic, ongoing product development of our customers' crusher liner sets and goes above and beyond standard industry practice of trialling a set of liners.

Utilizing state-of-the-art laser scanning in conjunction with H-E Parts ChamberVision™ and CrusherVision™ software, H-E Parts dedicated engineering specialists are able to accurately predict wear performance in cone, jaw and gyratory crushers to provide customized solutions to suit site-specific requirements.

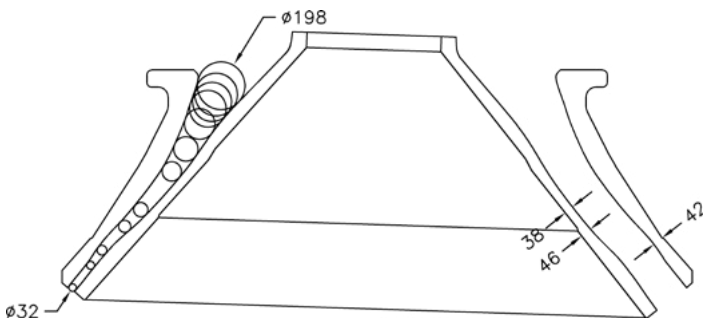

MODEL INTEGRATION

Combining the outputs of CrusherVision™ and ChamberVision™ allows changes in performance to be predicted as liners wear.

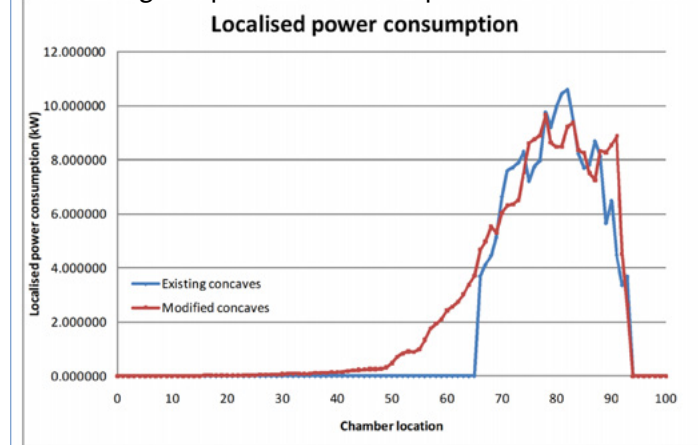

CRUSHERVISION™

CRUSHERVISION™ CRUSHER SIMULATION

Crusher wear simulations are performed with H-E Parts CrusherVision™ software, which is based on leading-edge academic research. CrusherVision™ advanced crusher model simulation software provides predictions of:

- Throughput.
- Power draw.
- Prediction of crushed product distribution.
- Scenario testing to estimate the effects of changing machine parameters such as speed and eccentric throw.
- Design-stage analysis tools to prevent issues such as chamber packing.

By combining the capabilities of the CrusherVision™ and ChamberVision™ software, crusher performance can be accurately predicted at all stages of the liner life.

LASER SCANNING

H-E Parts uses a state-of-the-art 3D laser scanner to provide fast 3D imaging of all liner surfaces for accurate wear models. By integrating the scan data with wear models and crusher performance models, the design becomes reliable and the need to periodically scan to measure wear rates becomes unnecessary.

ACTUAL SCAN OF A WORN CRUSHER MANTLE

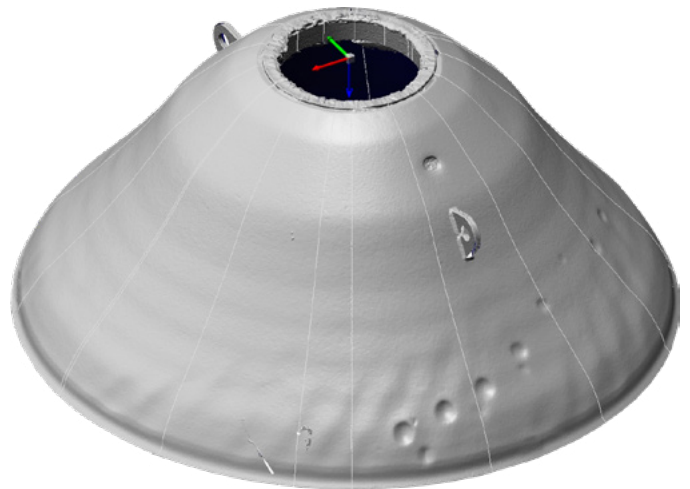

H-E Parts International replacement parts are compatible with the makes and/or models of the third-party equipment described. H-E Parts International is not an authorized repair facility of these third parties and it does not have an affiliation with any manufacturers of these third-party products. All brands, original equipment manufacturer (OEM) part numbers or references are owned by the respective OEM entities or their affiliates. These terms are used by H-E Parts International for identification and cross reference purposes only and are not intended to indicate affiliation with, or approval by the OEM, of H-E Parts International or its products.



CRUSHING SOLUTIONS

HEPI17JUL2019

www.h-eparts.com