

**INNOVATION.
NOT DUPLICATION.™**



CRUSHING SOLUTIONS

IMPACT TABLES UTILIZING H-E PARTS ANTI-VIBRATION MOUNTINGS

Heavy-duty impact tables from H-E Parts International (H-E Parts) which utilize anti-vibration mountings, are designed to meet the extreme conditions associated with mining and quarrying conveyor applications. Each table is custom-designed to meet client requirements, ensuring a perfect fit with the strength required for the job.

ABSORBING IMPACT

Anti-vibration mountings provide both impact absorption and damping to the CME™ impact table. The result is a substantial reduction in transmitted shock load to supporting steelwork and less damage to belts. Anti-vibration units rarely require replacement and have been proven to last more than eight years in some applications.

FORGET IDLER DAMAGE AND PRODUCT LEAKAGE

H-E Parts CME™ impact tables replace conventional impact rollers. The center section deflects on anti-vibration mounts to absorb impact and remove maintenance issues. H-E Parts CME™ impact tables also feature rigid side skirt supports to ensure that product stays on the belt where it belongs, while also reducing dust spillage.

FAST-CHANGE SLIDER BARS

CME™ impact tables feature anti-static, low friction polymeric slider bars, which are quickly changed using the incorporated unique T-tracking system. To change slider bars, users simply remove the two end bolts holding the retainer in place, removing the need for cumbersome 'T' bolts used in some other impact beds.

EXTENDED BELT LIFE

Because CME™ impact tables support the belt along the full length of the transfer point, belt tears due to product spearing between roller frames are a thing of the past. The result is longer belt life and less breakdowns.

DYNAMIC IMPACT TABLE INFO SHEET

CUSTOMER

CUSTOMER NAME:

APPLICATION:

DATE:

CONTACT NAME:

MOBILE:

DIRECT:

PHONE:

FAX:

SALESPERSON

RETURN TO:

EMAIL:

DIRECT:

PHONE:

MOBILE:

FAX:

ROLLERS AND CHUTE

DIMENSION A:

DIMENSION B:

DIMENSION C:

DIMENSION D:

DIMENSION SKIRT E:

IMPACT POINT LENGTH:

MATERIAL

TYPE:

SPECIFIC GRAVITY:

MAX. LUMP SIZE:

AVERAGE LUMP SIZE:

FLOW RATE (TPH):

SHARP ROCKS?

CONVEYOR

CONVEYOR NUMBER:

FREE FALL HEIGHT:

BELT WIDTH:

TROUGH ANGLE:

BELT SPEED:

IDLER DIAMETER:

IDLER SERIES:

IMPACT TABLE LENGTH:

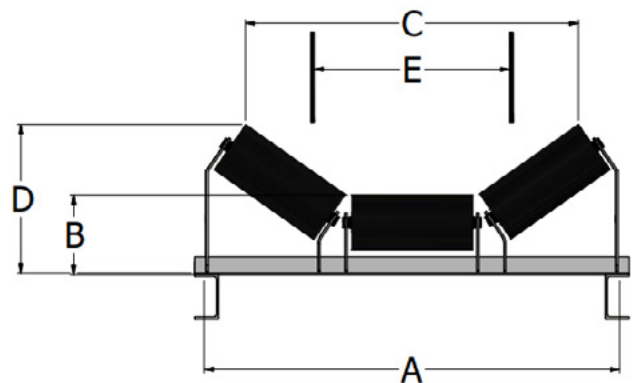

ADDITIONAL INFORMATION

H-E Parts International replacement parts are compatible with the makes and/or models of the third-party equipment described. H-E Parts International is not an authorized repair facility of these third parties and it does not have an affiliation with any manufacturers of these third-party products. All brands, original equipment manufacturer (OEM) part numbers or references are owned by the respective OEM entities or their affiliates. These terms are used by H-E Parts International for identification and cross reference purposes only and are not intended to indicate affiliation with, or approval by the OEM, of H-E Parts International or its products.



CRUSHING SOLUTIONS

HEP17JUL2019

www.h-e-parts.com