

BIRRANA A11699 BEST PLUG TO SUIT CAT 785, 789 & 793 REAR WHEEL GROUPS

Most accidents involving machine operation or maintenance are caused by failure to observe basic safety rules or safety precautions. Read and understand all safety precautions and warnings, before attempting installation and operation of the BEST plug.

H-E Parts International cannot anticipate every possible circumstance that may involve a potential hazard. You must comply with all mine-specific safety procedures, and satisfy yourself that any procedure, tool or operation method used is safe for yourself and others.

Refer to the truck manufacturer's repair and maintenance instructions in conjunction with these instructions where applicable. Obey all recommended safety instructions or warnings.

Before working on any equipment make sure that the work area is safe, and that the equipment is tagged and locked out in accordance with mine safety procedures.

The differential compartment may contain some residual pressure. The potential exists for hot oil to be expelled, causing scalds, burns or personal injury. Wear gloves and protective eyewear, and ensure care is taken when using or removing plugs.

INSTALLING THE BEST PLUG

1. Ensure the level plug is above the final drive oil level.
2. Remove the original level plug from the final drive cover.
3. Ensure that the washer face, and threaded hole for the level plug and surrounding area is clean.
4. Install the A11699 BEST plug into the level port. Torque as per the standard final drive level plug - tighten on the large hex only.

MAGNETIC DEBRIS INSPECTION

1. Remove the magnetic plug by unscrewing the small hex, ensuring that the main body remains in place in the final drive cover. The magnet can be inspected for debris.
2. Select a new B10569 plug, or clean the original plug's magnet.
3. Install the magnetic plug.

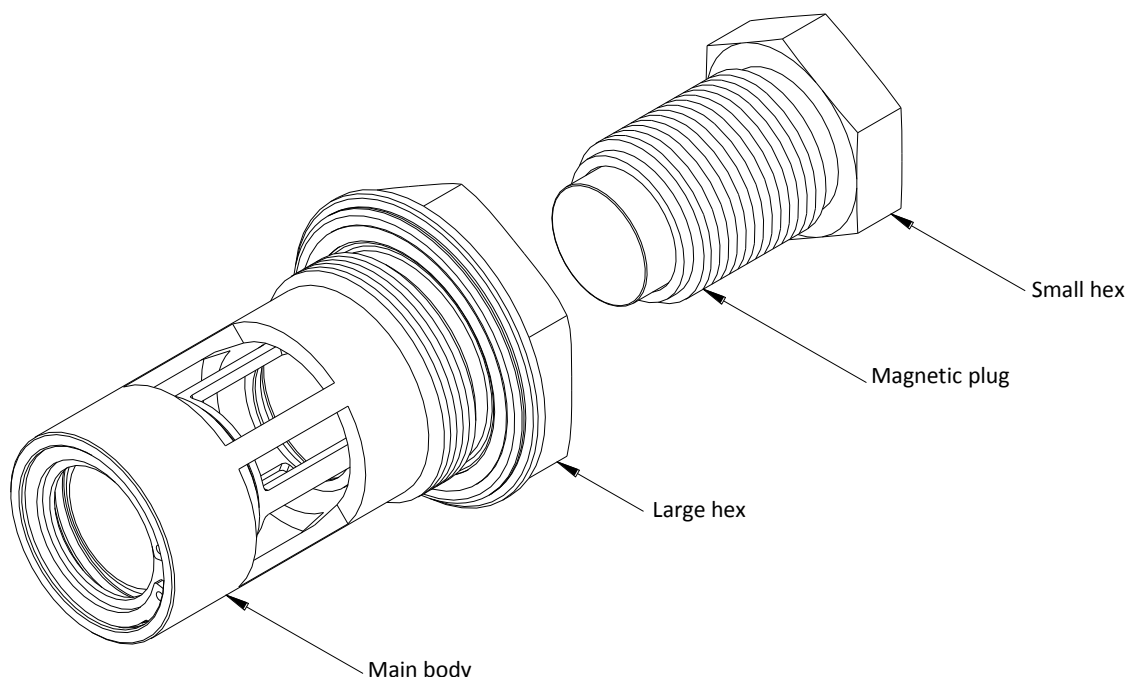

KIDNEY-LOOPING THE WHEEL GROUP OIL

1. Ensure the oil sampling plug is below the final drive oil level. Refer Figure 2.
2. Remove the magnetic plug by unscrewing the small hex. The magnet can be inspected for debris.
3. Ensure that a suitable dry-break / quick-connect coupling has been fitted to the B11535 adaptor. The B11535 has a female 3/4" NPT thread for this purpose.
4. Install the B11535 adaptor into the BEST plug body.
5. Connect the kidney-looping hose to the dry-break coupling.
6. Follow standard kidney-looping procedure. Note that a flow restriction may occur through the B11535 adaptor. Check that the kidney-looping system still functions correctly.
7. Disconnect and remove the B11535 adaptor when the kidney-looping has finished.
8. Select a new B10569 plug, or clean the original plug's magnet.
9. Install the magnetic plug.

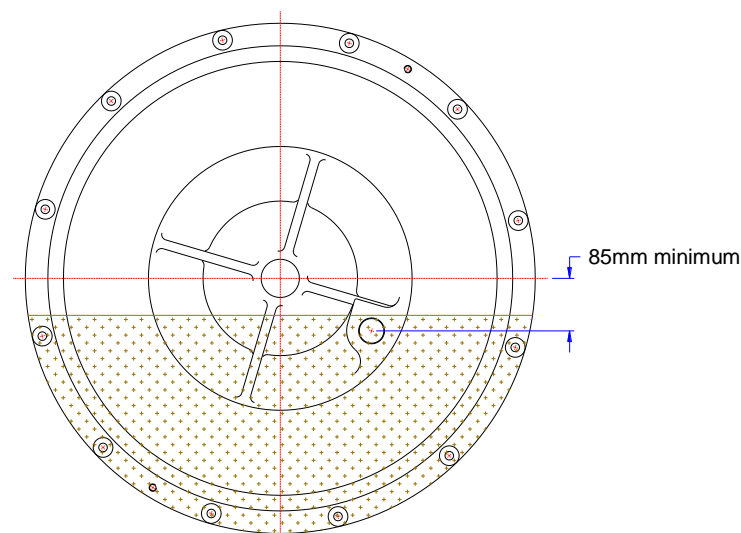

Figure 2

*If you require any further assistance with this procedure please contact your local H-E Parts representative.
Adelaide (08 8445 7755) Perth (08 9379 2718) Mackay (07 4952 5422) Newcastle (02 4964 9411)*