

BIRRANA A9930 OIL SAMPLING PLUG TO SUIT CAT 785 / 789 / 793 TRUCKS

Most accidents involving machine operation or maintenance are caused by failure to observe basic safety rules or safety precautions. Read and understand all safety precautions and warnings, before attempting installation and operation of this component.

H-E Parts International cannot anticipate every possible circumstance that may involve a potential hazard. You must comply with all mine-specific safety procedures, and satisfy yourself that any procedure, tool or operation method used is safe for yourself and others.

Refer to the truck manufacturer's repair and maintenance instructions in conjunction with these instructions where applicable. Obey all recommended safety instructions or warnings.

Before working on any equipment make sure that the work area is safe, and that the equipment is tagged and locked out in accordance with mine safety procedures.

The wheel group cavities may contain some residual pressure. The potential exists for hot oil to be expelled, causing scalds, burns or personal injury. Take care when using or removing plugs.

INSTALLATION

1. Ensure the level plug is above the final drive oil level.
2. Remove the original level plug from the final drive cover.
3. Ensure that the threaded hole in the cover for the level plug and surrounding area is clean.
4. Install the A9930 oil sampling plug. Torque the body as per the standard final drive level plug.

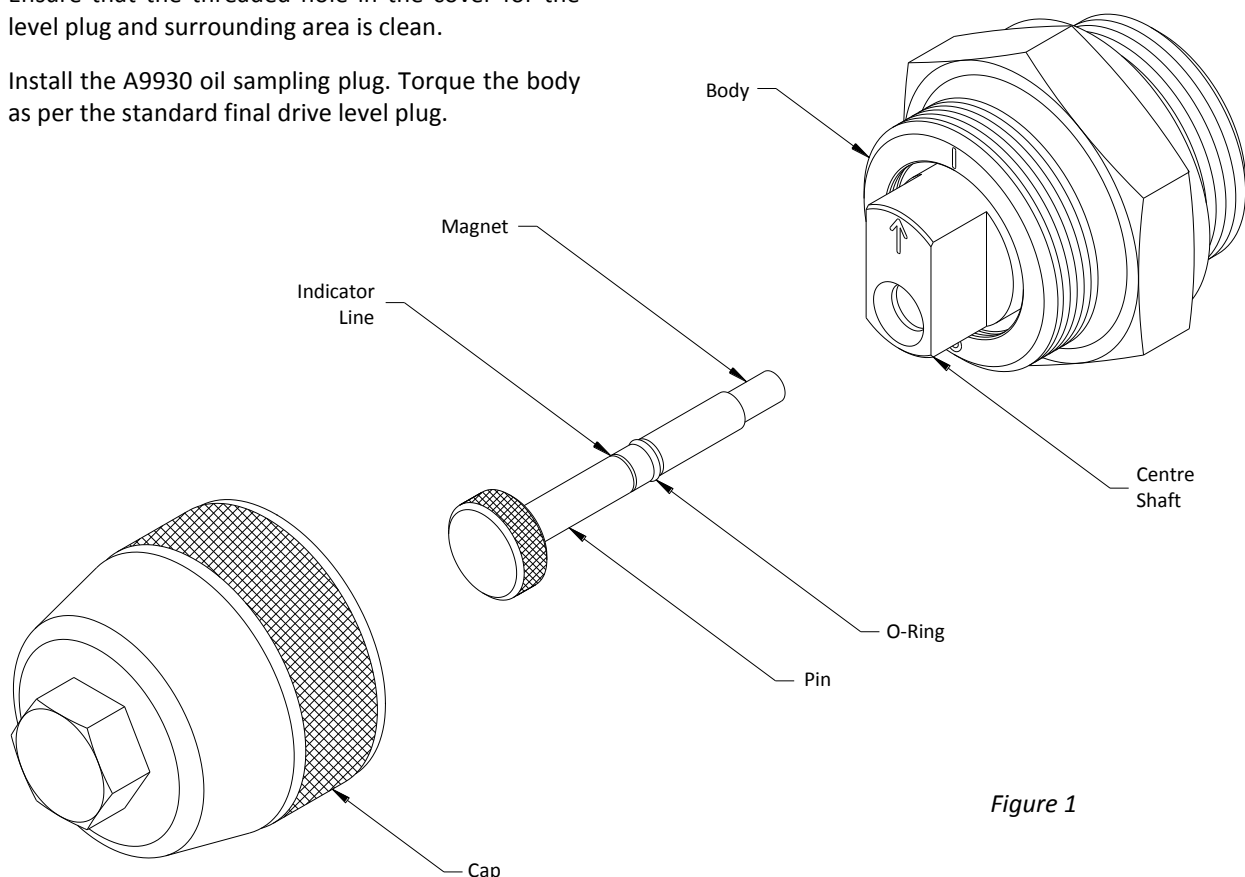

Figure 1

**PROCEDURE FOR MAGNETIC DEBRIS
INSPECTION**

1. Remove the cap.
2. Partially slide out the pin, until the indicator line is visible.
3. Rotate the centre shaft through 180° to the position shown in Figure 2. A 5/8" (16mm) spanner can be used on the shaft flats if required.

Note: The port is now closed and sealed.

4. Fully remove the pin. The magnet can now be inspected for debris.
5. Select a new B9925 pin, or clean the original pin's magnet. Insert the pin into the centre shaft, until the o-ring engages inside the shaft (the indicator line will still be visible).
6. Rotate the centre shaft through 180° to the position shown in Figure 3.
7. Press the pin into the centre shaft, until it is fully engaged.
8. Install the cap. Tighten the cap until the o-ring is compressed and the cap end face touches the body (approximately 35Nm / 25ft.lb required). Do not over-tighten. The cap can be tightened by hand, or by using a spanner on the 5/8" (16mm) hex.

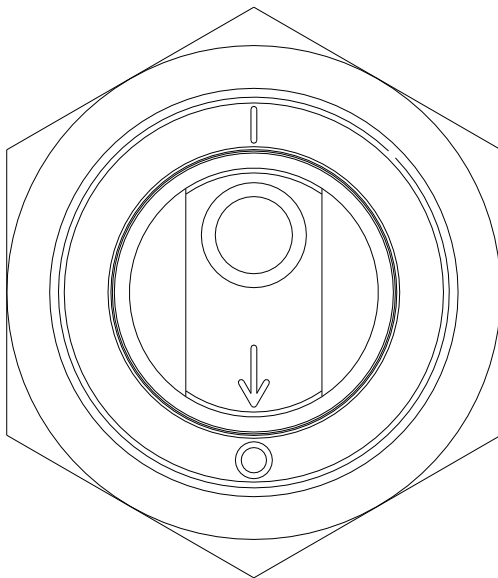

*Figure 2
(Port is closed
and sealed)*

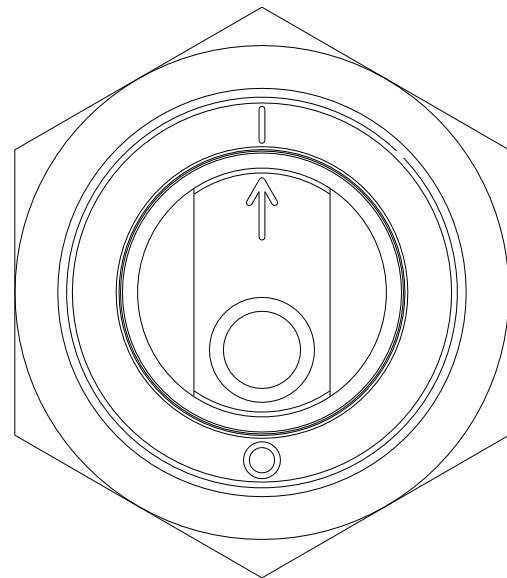

*Figure 3
(Port is open)*

PROCEDURE FOR OIL SAMPLING & MAGNETIC DEBRIS INSPECTION

1. Ensure the oil sampling plug is below the final drive oil level. Refer Figure 4.
2. Remove the cap.
3. Partially slide out the pin, until the indicator line is visible.
4. Rotate the centre shaft through 180° to the position shown in Figure 2. A 5/8" (16mm) spanner can be used on the shaft flats if required.

Note: The port is now closed and sealed.

5. Fully remove the pin. The magnet can now be inspected for debris.
6. Insert the 5/16" oil sampling tube (CAT Part No 4C-4056) into the hole in the centre shaft. Draw a line on the tube with a permanent marker, level with the end of the centre shaft.
7. Rotate the centre shaft through 180° to the position shown in Figure 3.
8. Feed the tube through the plug assembly, inside the final drive compartment.

Note: To ensure consistent oil samples, it is recommended that the length of tube fed into the final drive compartment be consistent between samples.

9. Take the oil sample as per standard procedure.
10. Pull the oil sampling tube outwards, until the marked line (from step 6) can be seen.
11. Rotate the centre shaft through 180° to the position shown in Figure 2.

Note: The port is now closed and sealed.

12. Remove the oil sampling tube from the centre shaft.
13. Select a new B9925 pin, or clean the original pin's magnet. Insert the pin into the centre shaft, until the o-ring engages inside the shaft (the indicator line will still be visible).
14. Rotate the centre shaft through 180° to the position shown in Figure 3.
15. Press the pin into the centre shaft, until it is fully engaged.
16. Install the cap. Tighten the cap until the o-ring is compressed and the cap end face touches the body (approximately 35Nm (25ft.lb) required). Do not over-tighten. The cap can be tightened by hand, or by using a spanner on the 5/8" (16mm) hex.

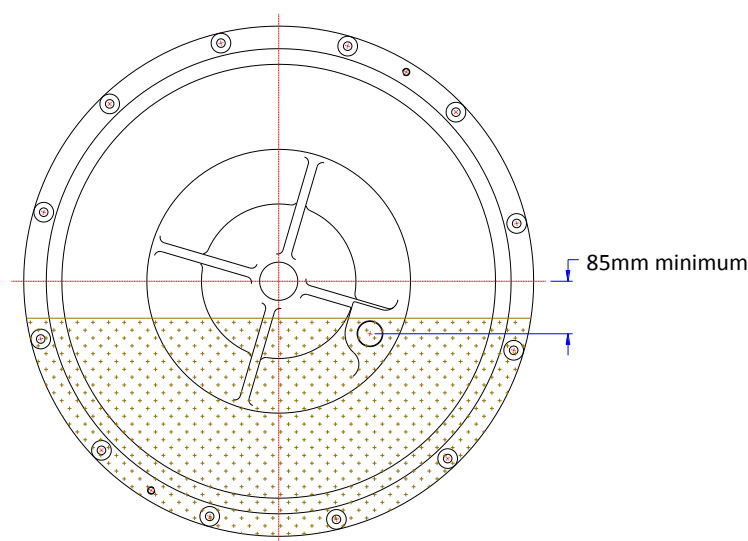

Figure 4

If you require any further assistance with this procedure please contact your local H-E Parts representative.

Adelaide (08 8445 7755) Perth (08 9379 2718) Mackay (07 4952 5422) Newcastle (02 4964 9411)